

Sine encoders

Solid shaft with synchro flange

1024...5000 sinewave cycles per turn

OGS 71



OGS 71

Features

- Solid shaft $\varnothing 6$ mm
- Up to 5000 sinewaves cycles per turn
- SinCos output-signals 1 Vpp
- Low harmonic content (patented LowHarmonics technology)
- Compact, robust die-cast housing
- Inside connecting terminals
- High protection IP 66

Technical data - electrical ratings

Voltage supply	5 VDC ± 10 % 9...30 VDC
Consumption w/o load	≤ 90 mA
Sinewave cycles per turn	1024...5000
Phase shift	90°
Reference signal	Zero pulse, width 90°
Sensing method	Optical
Output signals	K1, K2, K0 + inverted
Output stages	SinCos 1 Vpp
Difference of SinCos amplitude	≤ 20 mV
Harmonics typ.	-50 dB
DC offset	≤ 20 mV
Bandwidth	250 kHz (-3 dB)
Interference immunity	EN 61000-6-2
Emitted interference	EN 61000-6-3
Approvals	CE, UL approval / E256710

Technical data - mechanical design

Size (flange)	$\varnothing 58$ mm
Shaft type	$\varnothing 6$ mm solid shaft
Admitted shaft load	≤ 30 N axial ≤ 40 N radial
Flange	Synchro flange
Protection DIN EN 60529	IP 66
Operating speed	≤ 10000 rpm (mechanical)
Operating torque typ.	1 Ncm
Rotor moment of inertia	25 gcm ²
Materials	Housing: aluminium die-cast Shaft: stainless steel
Operating temperature	-20...+85 °C
Resistance	IEC 60068-2-6 Vibration 10 g, 10-2000 Hz IEC 60068-2-27 Shock 300 g, 6 ms
Explosion protection	II 3 G Ex nA IIC T4 Gc X (gas) II 3 D Ex tc IIIC T85°C Dc X (dust)
Connection	Connecting terminal
Weight approx.	350 g

Sine encoders

Solid shaft with synchro flange

1024...5000 sinewave cycles per turn

OGS 71

Output signals

at positive direction of rotation

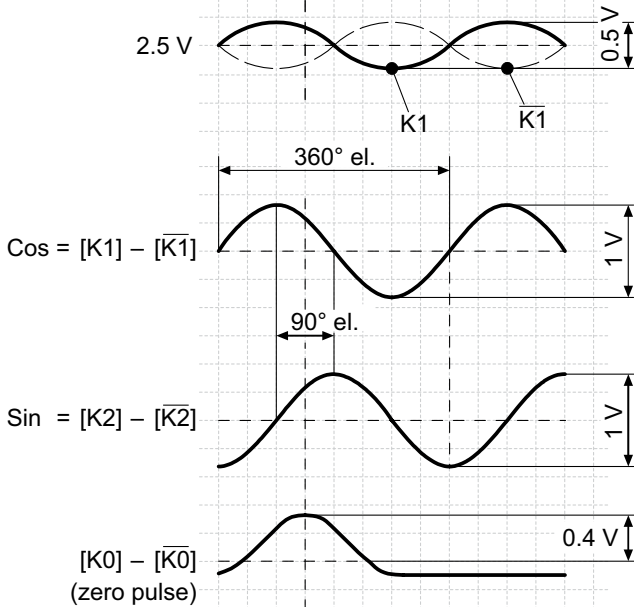

Terminal assignment

View A - Connecting terminal inside the encoder

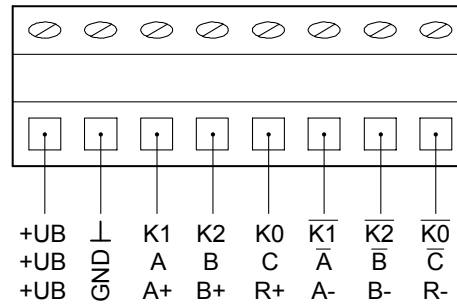

Dimensions

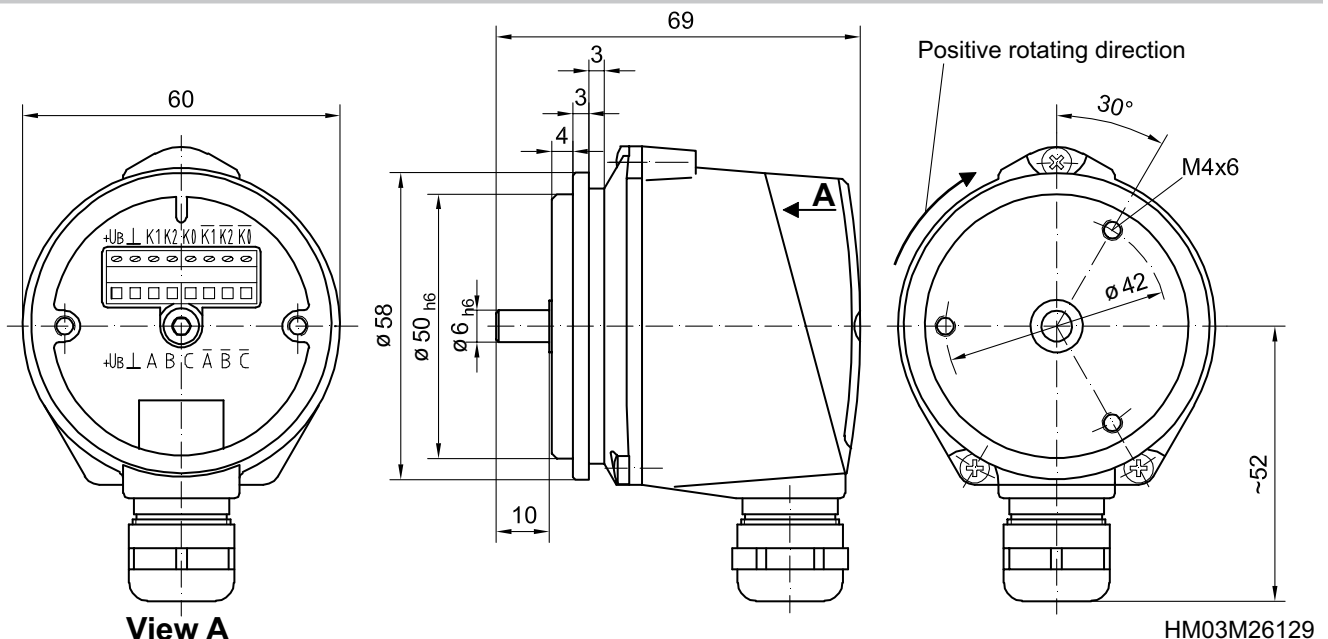

Sine encoders
Solid shaft with synchro flange
1024...5000 sinewave cycles per turn

OGS 71
